

Smarter luminaires

with the zencontrol Smart driver



zencontrol

zencontrol.com

To make buildings smarter, the luminaire needs to be smarter

The zencontrol driver (zc-driver) is an LED driver for connected luminaires designed to make the most out of leading technologies in control, automation and connectivity.

Code / description	DT6 mode, single channel	DT8 mode	DT6 mode, dual output
Operating voltage	~ 220 - 240 V 50 Hz	~ 220 - 240 V 50 Hz	~ 220 - 240 V 50 Hz
Power factor	> 0.98	> 0.98	> 0.98
Operating temperature	0 to 55°C	0 to 55°C	0 to 55°C
Dimming	1 - 100 %	10 - 100 %	1 - 100 %
Output	Power	40 W	2 x 20 W
	Voltage	9 - 39 V dc	9 - 39 V dc
	Current	0 - 1.2 A	0 - 0.6 A
	LED channels	1	2
Battery	LiFePO ₄ (with support for NiCd and NiMH)	LiFePO ₄ (with support for NiCd and NiMH)	LiFePO ₄ (with support for NiCd and NiMH)

What is a Smart luminaire?

The definition of a smart luminaire is inconsistent between manufacturers and marketing teams, with no definition of how a smart luminaire should perform. In zencontrol's definition, we think a smart luminaire should be able to provide the features that can help make a building smart and our smart driver delivers on that promise. Below is a general understanding of what zencontrol's Smart driver delivers.



Control

- Provides standalone control and easy configuration through IR (IEC62386-302) or DALI (IEC62386-102/103)
- Allow standardised lighting control, through DALI (IEC62386-102/103)
- Dimmable control, through push-buttons or DALI control systems (IEC62386-207, IEC62386-209)
- Provides occupancy detection within a room (IEC62386-303)
- Measures the light level below the luminaire (IEC62386-304)



Data

- Measures the light level and changes to the light level over time as well as measuring the minimum and maximum levels
- Measure and record its power consumption over time (IEC62396-253), including the control gear and devices
- Record occupancy details such as occupancy rates and occupancy activity
- Detail lamp, driver and battery life (IEC62386-102/202)
- Detail emergency test results (IEC62386-202)



IoT

- Individually identified (IEC62386-102/103)
- Individually controllable (IEC62386-102)
- Ability to use wired (IEC62386-101) or wireless control (IEC62386-104)
- Ability to be secure when using external connections to the internet/Cloud



Driver

- Support LED technology (IEC62386-207)
- Support tuneable white installations (IEC62386-209)
- Support emergency configurations (IEC62386-202)
- Reduced flicker when dimmed (i.e. low flicker across the dimmed range, not just at 100% output)



Installation

- Easy to install, suits plug and play configuration
- Easy to add sensors or emergency, without DALI current limits
- Allows for a full DALI installation (with up to 64 LED drivers, 64 emergency devices and 64 DALI sensors and switches per DALI line)
- Reduce the number of addresses in a building
- Allow for simple installation into a luminaire for the OEM
- Reduce the total overall cost of the installation



Power

- Low standby power, even when using wireless attachments
- Efficient, total system power is efficient even with add on sensors/emergency and other technology

Preliminary

Pluggable accessories

The smart driver supports plug and play add-ons to provide smart functionality.

The addition of sensors, emergency spots and exits is achieved via a pluggable RJ12 cable. Two ports are provided allowing both a sensor and emergency add-on to be connected simultaneously.

The add-on sensor provides the ability for motion detection via passive infra-red (PIR) or microwave technology using IEC62386-303. Each sensor also contains a digital light level sensor allowing for daylight harvesting using IEC62386-304 and an infrared sensor for programming through an IR remote.

The addition of a sensor does not increase the DALI line current allowing the use of up to 64 sensors per DALI line. Additionally, the sensors power consumption averages less than 50 mW, which in comparison to traditional sensors provides significant power saving. *(Typically installing a sensor in every luminaire consumes less power than the traditional installation method).*

Multiple mounting options are available for installers and building owners. The Nano sensor has been designed to be installed into sheet metal or directly into the luminaire with a 14 mm circular cut-out.

The 5m and 8m PIR sensor or emergency spot can be installed directly into the luminaire or installed adjacent with a recessed mounting kit. On concrete ceilings the surface mounting or conduit mounting kit can be used.

OEMs can choose to mount the plug-in accessories directly into their luminaire or allow for external mounting, however when the sensors are installed within the luminaire the on-site installation costs can be reduced dramatically.

Due to the plug and play nature of the zencontrol smart driver, an installer can add a smart accessory any time after installation.

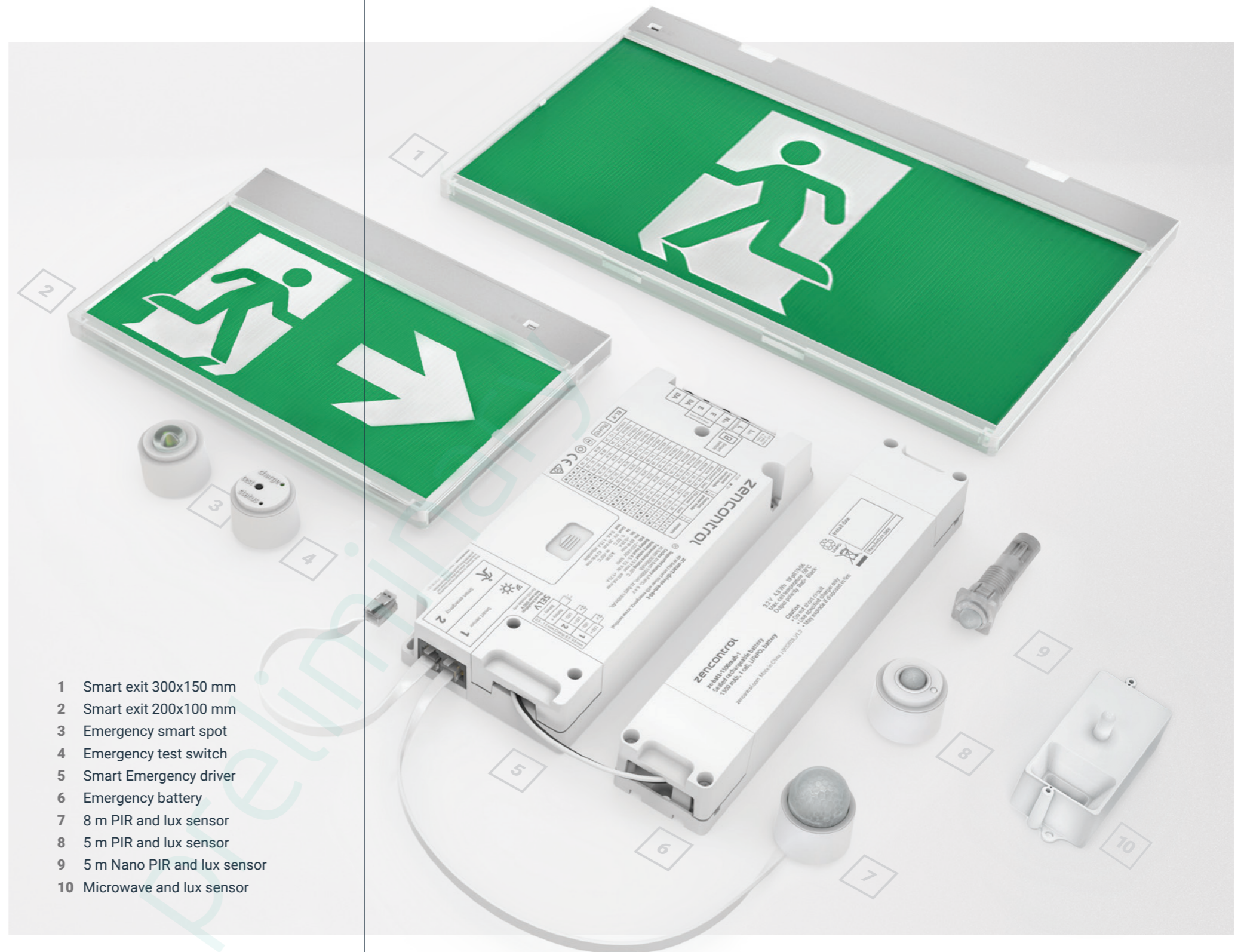

- 1 Smart exit 300x150 mm
- 2 Smart exit 200x100 mm
- 3 Emergency smart spot
- 4 Emergency test switch
- 5 Smart Emergency driver
- 6 Emergency battery
- 7 8 m PIR and lux sensor
- 8 5 m PIR and lux sensor
- 9 5 m Nano PIR and lux sensor
- 10 Microwave and lux sensor



Inbuilt Nano

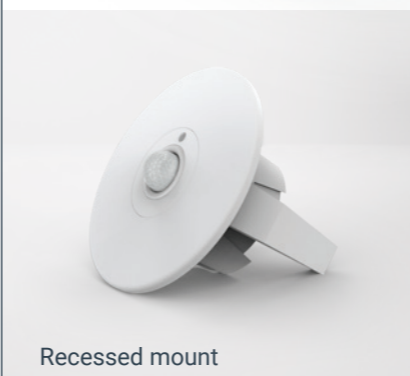

Recessed mount



Surface mount



Conduit mount

Dual channel output

The Smart driver offers dual channel output providing enhanced capability in several applications.

Tunable white

The zc-driver provides the ability of full scale Correlated Colour Temperature (CCT) tuning when paired with dual colour fittings.

Unlike current offers that provide only two or three selectable colour options, the scalable dual channel output of the zc-driver allows practically limitless colour temperature options between the luminaires warmest and coolest colour output using IEC62386-209.

By balancing colour temperature you may influence office work-flow, increase comfort and productivity in the building.

The fine control allowed by the zc-driver, empowers applications from time of day colour coordination to full circadian rhythm integrations for facilities looking to provide the optimal workplace environment.

By default, when an OEM installs two separate channels of LEDs into the zencontrol Smart driver, the driver will detect the second channel and automatically enable device type 8 allowing configuration and control from a DALI control system.

Long life fittings

The cost of replacing and maintaining traditional luminaires over a standard lifetime is often a significant proportion of total cost of ownership.

The zc-driver supports long life luminaires by enabling the use of redundant LED light sources, effectively doubling the rated life of any LED used in a luminaire. During its life two different LED sources are interchanged by the smart driver. When combined with LEDs with a L70 life of > 50K hours, fittings can be designed for 10 year life-cycles.

Dual luminaire

Installations looking for a more optimal solution may consider the Smart drivers dual luminaire mode.

Traditionally, two light fittings connected to a single driver has been problematic. In a series connection, a single fitting failure would result in both fittings failing, while in a parallel connection, voltage drop and loading would cause significant issues.

The Smart driver has two independent outputs allowing optimal performance and correct control of each luminaire. In the event of a single luminaire failure the second luminaire will continue to function.

Using the dual luminaire mode provides significant benefits including cost savings, waste reduction and power savings.

The dual luminaire mode provides the following savings:

- Requires only one mains connection point per 2 luminaires
- Requires only one driver per 2 luminaires
- 50% less control system components and lower commissioning costs
- Lower overall impact on the environment
- Reduced failure rate in the building
- Reduced standby power
- Better efficiency
- Reduced waste

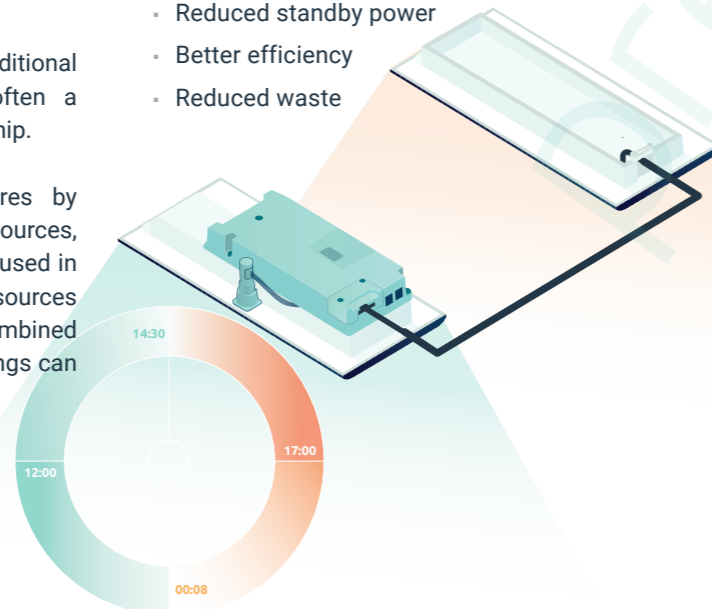

Corridor mode

Upgrading any luminaire with a PIR sensor is as easy as plugging it in.

zencontrol pluggable sensor supports PIR, lux, colour, CRI and Ra sensing. The sensor is powered directly from the zc-driver and does not use any DALI line current, preserving maximum DALI device support.

zencontrol Smart drivers include their own application control, which when not connected to a DALI control system can operate independently.

When newly installed and not connected to DALI, the Smart driver will use the connected sensors (mains rated or RJ12) to detect motion. In this mode, the smart driver will control the lighting, turning the lighting off after the motion has stopped. This solution is ideal for car parks, stairs or standalone office installations.

Additionally, when using smart sensors which include IR the behaviour including timeouts and off states can be fully configured.

- 1 Luminaire is off
- 2 Luminaire is activated by sensor
- 3 Luminaire fades to comfort level
- 4 Luminaires can remain at comfort level indefinitely
- 5 Luminaires turn off after comfort time when minimum illumination is not required

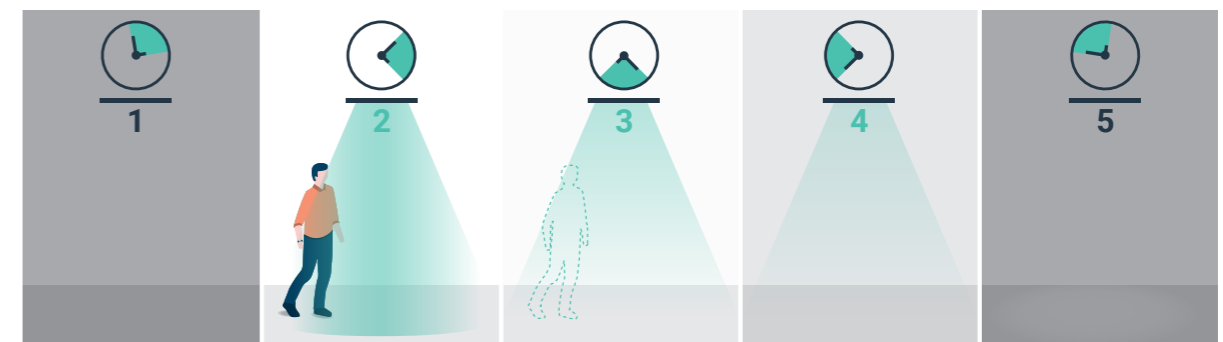

Daylight harvesting

Using daylight harvesting installers can reduce the energy consumption in a building.

A standalone system can use the IR remote to configure daylight harvesting on each luminaire without the need for a control system.

For an installation which uses a lighting control system, the light level sensor in each luminaire can be used by the controllers, however, when deploying a large number of light sensors the amount of traffic on the DALI line may be too high.

An alternative approach is individual light level control, where each fitting is controlled independently. To achieve this solution, each zencontrol Smart driver has its own internal application controller which controls the connected fitting without directing traffic onto the DALI line.

This technique serves to deliver the following benefits:

- Lower bus traffic
- Faster control of each light fitting
- Maximum energy savings
- Precision lighting across the floor

While in this mode commissioning can be executed using the DALI control system or an IR remote control.

Plug in emergency

The zencontrol Smart driver has an inbuilt battery charger and emergency LED driver allowing the addition of smart emergency add-ons which support the following supported modes.

- **Inverter mode:** powers the main LEDs in emergency
- **Exit mode:** powers a maintained emergency exit
- **Spot mode:** powers a standalone non-maintained emergency LED spot

Modes are enabled by plugging the accessory into the driver.

DALI monitored emergency testing

When using a smart plug-in emergency option, the driver supports IEC62386-202, device type 1 allowing for emergency testing and management. Additionally, the driver can perform as a self-test unit or in standalone configuration.

As the emergency and standard LED driver is in the same product, only one DALI address is consumed, lowering the cost of additional control system components. The following benefits are achieved:

- Less DALI addresses as the emergency and standard lighting share the same address
- Additions or extra emergency devices are simple and easy, as they just plug in and don't require an additional address
- Emergency testing can still be performed without affecting the normal lighting
- Lower standby power
- Lower power consumption as devices are converged
- Emergency lights can be built into the luminaire reducing installation costs
- Lower failure rate in the building as less devices are installed
- Lower commissioning cost as there are less addresses
- Lower overall cost

Lithium batteries

Environmentally friendly Lithium Iron Phosphate batteries are used on the Smart driver reducing the effects of heavy and highly polluting material found in Cadmium and Lead Acid batteries.

Smart battery charging technology ensures the battery is charged quickly after discharge but also reduces the overall power consumption as the charger remains in a standby state only topping up the battery when required.

This smart technology allows up to 10 years of battery life on some configurations. As a result of the Smart charger and technology in the zencontrol Smart driver, the overall power consumption is dramatically less than competing products.

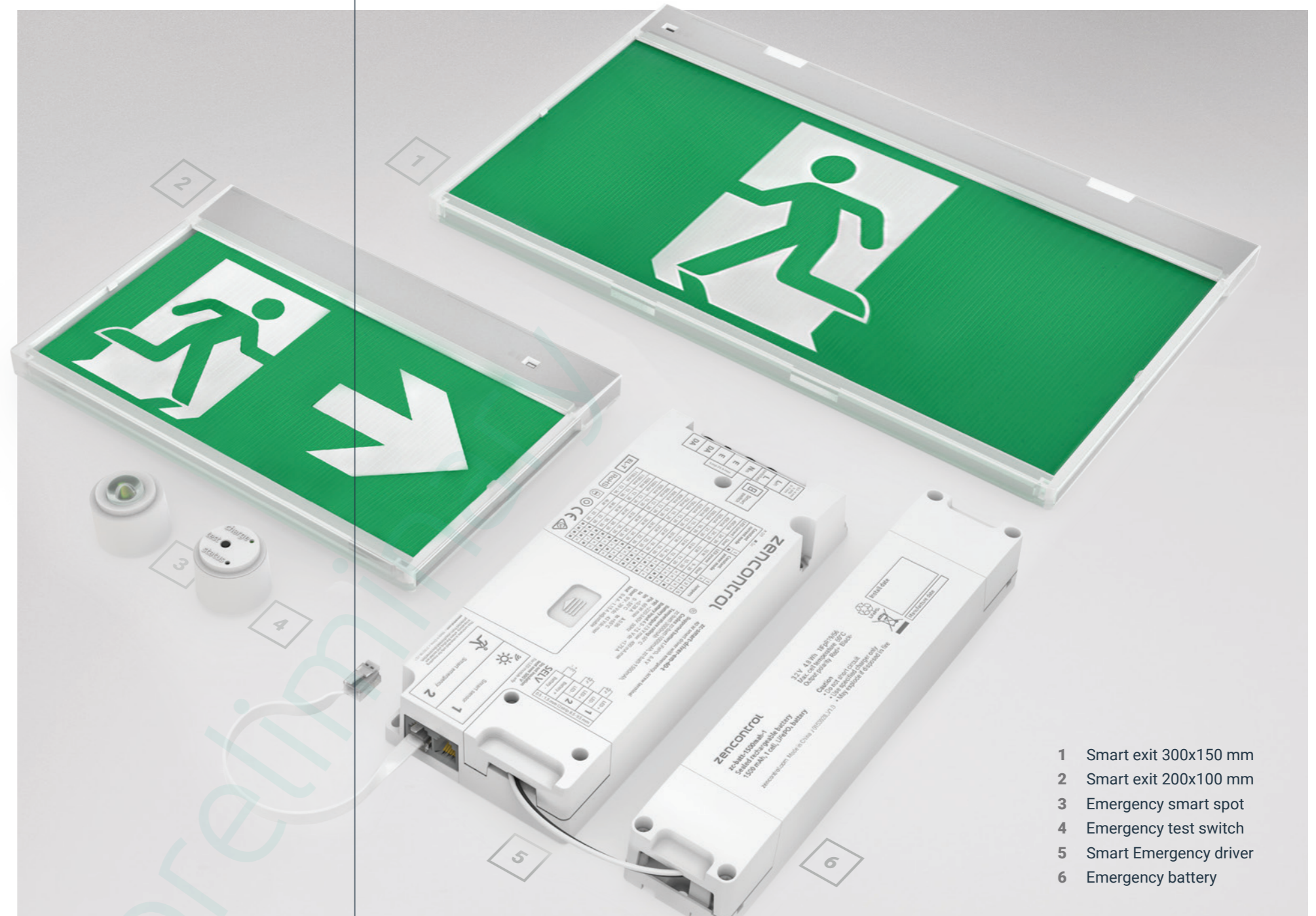

- 1 Smart exit 300x150 mm
- 2 Smart exit 200x100 mm
- 3 Emergency smart spot
- 4 Emergency test switch
- 5 Smart Emergency driver
- 6 Emergency battery

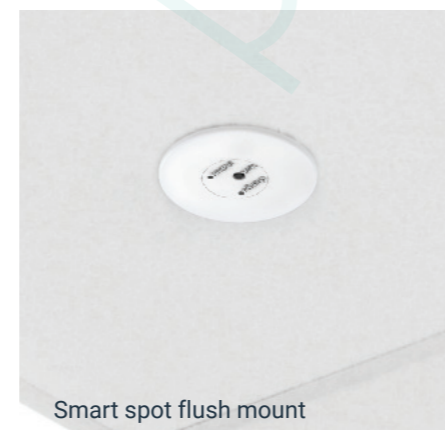

Smart spot flush mount



Surface mount

Pendant mount

Wall mount

Mains rated DALI switches & sensors

Convert standard switches and sensors into DALI compliant add-ons.

A zencontrol Smart driver has a switch active input which can be used with mains rated switches or sensors. This gives the installation flexibility with its design and also serves to reduce overall cost.

The switches input can be wired to support the following:

- A mains rated on / off switch
- A mains rated momentary switch
- A mains switching sensor (supporting any technology)
- A mains switching control system input

When installed the zencontrol Smart driver will automatically switch between a push button control (IEC62386-301) or sensor input (IEC62386-303).

When a mains rated device is installed the following modes will be setup by default:

Device	DALI power & addressed	LED mode	Action
Momentary switch	No	DT6	Push button dimmer
Momentary switch	No	DT8	Colour dimmer
Mains sensor	No	DT6 or DT8	Corridor mode
On / off switch	Any	Any	Needs configuration

* For installations which connect to a DALI control system and set the control device address, the switch or sensor will operate as a fully configurable DALI edition 2 device (IEC62386-301 / 302 / 303) which can be used by the connected control system.

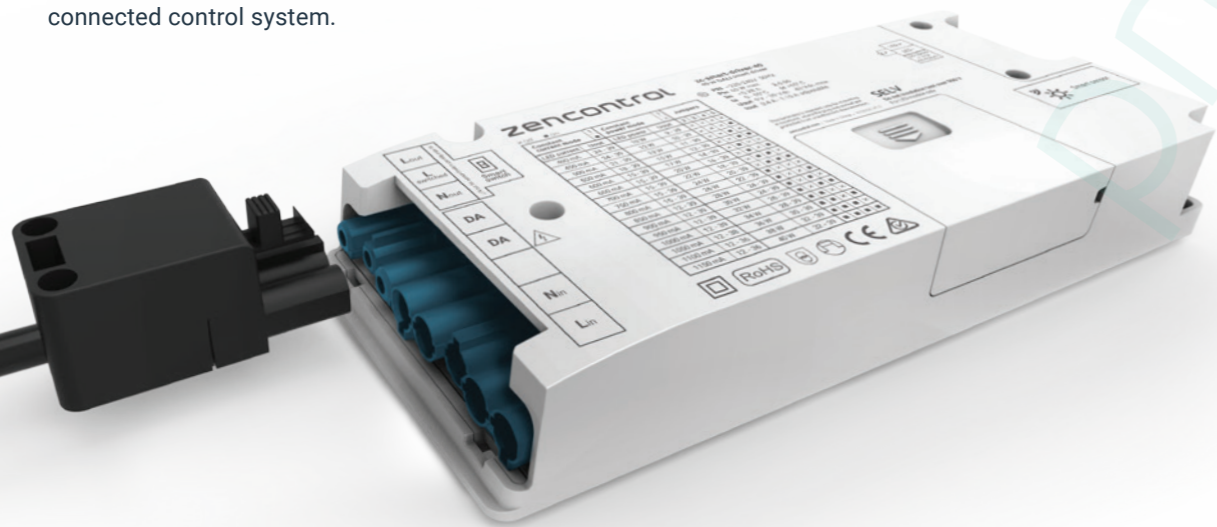
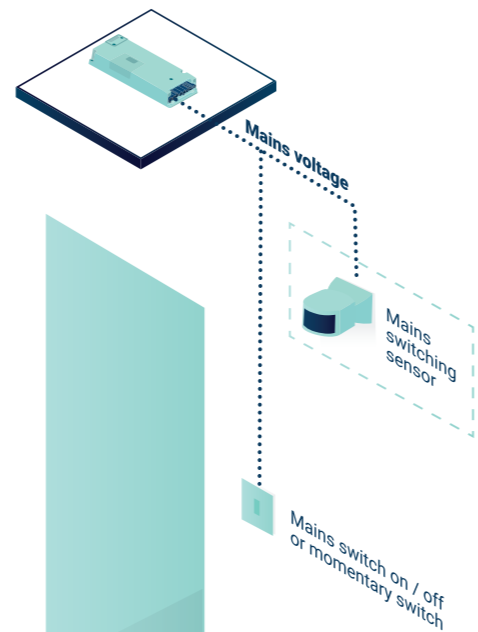

Power or current

Precision constant power drivers offer consistent output and removes issues with forward voltage variation.

Variations in LED forward voltages can cause thermal and lumen output issues for luminaire designers. LED forward voltage can change due to batching, temperature, age and drive current. For a constant current fitting using LEDs with a typical forward voltage between 2.8-3.6V the power difference between luminaires can be up to 20%.

Power fluctuations from changes in LED forward voltage, luminaire designers need to manufacture fittings to handle worst case thermal conditions. Due to the variance in thermal load, fittings can require larger heat-sinks or a more expensive construction when compared to a constant power solution.

Using constant power output, luminaire designers can achieve a consistent light output, as well as benefit from easier thermal management, batch management and manufacturability.

Constant current mode

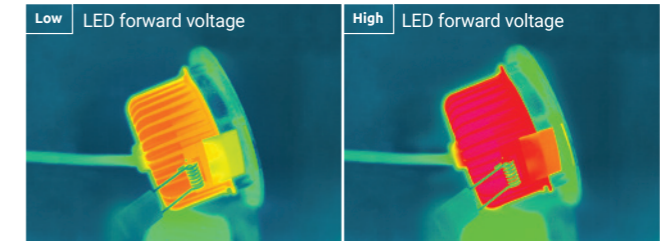

Thermal output increases with increased forward voltage

Constant power mode

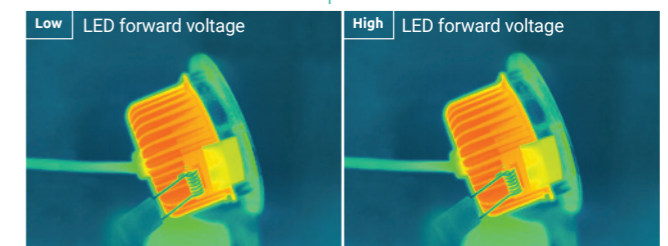

Same thermal output regardless of LED forward voltage

Selecting output

zc-drivers have selectable output of both current and power. Constant current models allow compatibility with existing designs and follow industry standard convention.

Constant power output allows consistent power output for a given set point, regardless of the particular configuration of the LEDs, LED forward voltage or change in LED voltage through temperature, colour selection or aging. This provides designers and manufacturers flexibility in LED designs and simplifies the models and model configurations needed.

When set to a particular output wattage, constant power zc-drivers will scale the output current automatically based on the measured LED voltage.

Adjusting the set point is as simple as configuring the jumpers located under the daughterboard cover.

Jumpers				Constant current mode			Constant power mode		
a	b	c	d	LED current	V min.	V max.	Power	V min.	V max.
□	□	□	□	400	24	39	10.0	9	39
□	□	■	□	450	24	39	12	10	39
□	■	□	□	500	21	39	13	10	39
□	■	■	□	550	18	39	15	11	39
□	■	■	■	600	15	39	17	12	39
■	□	□	□	650	15	39	20	14	39
■	□	■	□	700	15	39	22	18	39
■	□	■	■	750	15	39	24	20	39
■	■	□	□	800	15	39	26	22	39
■	■	■	□	850	12	39	28	24	39
■	■	■	■	900	12	39	30	24	39
■	■	■	■	950	12	39	32	26	39
■	■	■	■	1000	12	39	34	28	39
■	■	■	■	1050	12	38	36	30	39
■	■	■	■	1100	12	36	38	32	39
■	■	■	■	1150	12	35	40.0	32	39

Preliminary information is subject to change without notice, E&OE

zencontrol Smart luminaire

zencontrol.com

Last updated 11 November 2019 V2.1

Driver link

Achieve a smart room configuration without the need for complex lighting control systems.

Easy configuration of:

- **Occupancy control**
- **Daylight harvesting**
- **Dimming control**

- 1 Driver link connection**
Connect two drivers together via an RJ12 driver-link cable to suit a small office.
- 2 Inbuilt sensor**
Movement, light level and IR sensors built into the luminaire provides increased functionality and energy savings.
- 3 IR setup**
Use the IR remote control to program the operation of the room, including time-outs, overrides, daylight harvesting and many other features.
- 4 Multiway dimming**
Simply add switches to each driver for multiway dimming or other tasks.
- 5 Absence mode**
Setup a switch with sensors to operate in Absence mode.
- 6 Expandability**
Connect a DALI control system for expanded functionality, monitoring and control (optional).
- 7 Slave luminaire (optional)**
Slave luminaire connected to the second output channel on the driver (max 2x20W).

Smart office

A standalone smart solution

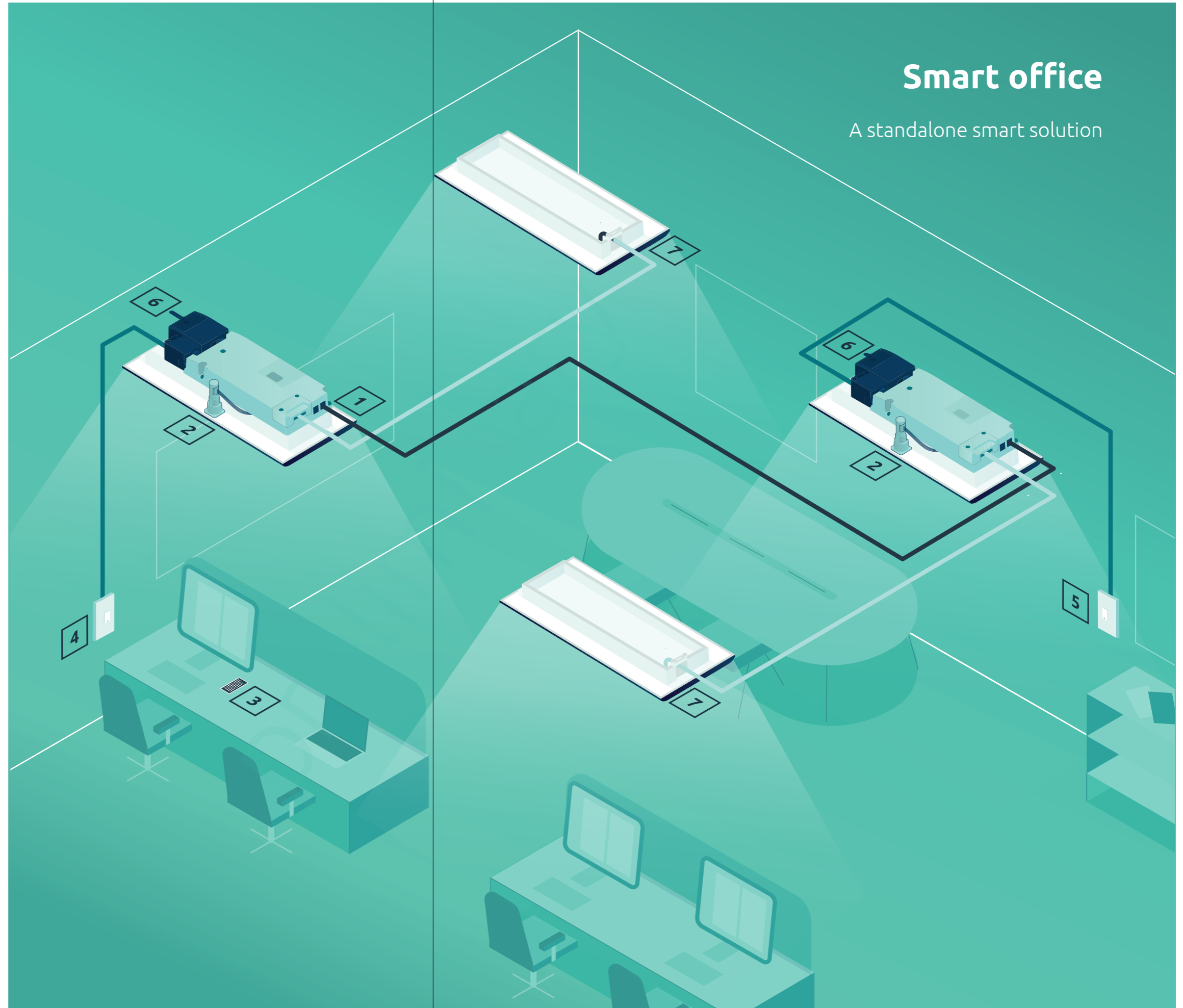

DALI-2

The zencontrol product range has been built for compliance with IEC62386 and IEC62386 edition 2.



Compliance

Much of zencontrol's automation and simple control is built on the functions and commands from the latest versions of the DALI standard. Full compliance with DALI standards ensures that connected devices behave as expected to ensure a consistent experience through the system life cycle.

The zc-driver has been built for compliance with IEC62386 and IEC62386 edition 2. Push buttons, switches and sensors connected through the zc-driver additionally comply with the particular requirements for each class of input devices.

DALI compliance does not just benefit zencontrol systems. DALI compliance provides a more reliable and simpler commissioning process on all DALI control systems.

DALI standards

The zc-driver supports the following DALI standards:

IEC 62386	Description
Part 101 ed 2	System components
Part 102 ed 2	Control gear
Part 103 ed 1	Control devices
Part 202	Self-contained emergency lighting (device type 1)
Part 207	LED modules (device type 6)
Part 209	Colour change (device type 8)
Part 220	Emergency DC
Part 252	Energy Reporting
Part 301	Input devices – Push buttons
Part 302	Input devices – Absolute input devices
Part 303	Input devices – Occupancy sensor
Part 304	Input devices – Light sensor
Part 305	Input devices – Colour sensor (upgradeable)

Flicker free

For optimal comfort, consultants and occupiers demand high quality flicker free drivers.

Flicker free has become more of a marketing term, and recently more people have been referring to the flicker index.

Regardless of how we interpret flicker free, ultimately reducing flicker is the solution to reduce eye strain and provide a better working environment.

One major area which tends to be overlooked is the amount of flicker produced when a driver is dimmed.

For many drivers, when they are dimmed the flicker is dramatically increased and this is typically due to the technology being applied. In a smart building, where lighting is often in a dimmed state, this is a significant problem.

To solve this, zencontrol has deployed technology that controls the flicker throughout the full dimming range. This technology helps to deliver a smarter building which produces quality light while reducing eye strain



Flexible installation

Designed with OEMs in mind

Inbuilt for OEM customers and drivers built into luminaires, where soft wiring is not practical, the zc-driver provides large cage clamp screw terminals with inbuilt earth termination, as shown in *fig 2*. As a result no additional terminal block is required, simplifying wiring and reducing cost.

Field mounting using Wieland GST1815 compatible plugs, connecting the driver to any soft wiring system is as simple as plugging it in, as per *fig 3*. zencontrol can supply leads for most lighting control soft wiring systems.

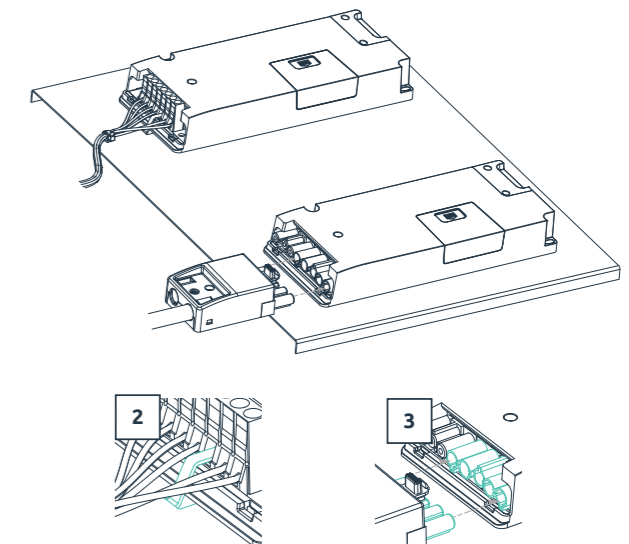



visit us at
zencontrol.com

zencontrol

